

FIT 2-M6 PUL-SERTS ITEM 18 TO LINK BAR IN POSITIONS SHOWN.

NOTE!
ASSEMBLY POSITION CAN BE VARIED TO LOCATE MOTOR AT LOWER POSITIONS BY INCREMENTS OF 75mm. AS LONG AS THE CONTROL ARM ITEM 4 IS NOT POSITIONED LOWER THAN THE 3rd. PITCH FROM THE BOTTOM OF THE LINK BAR AS SHOWN.

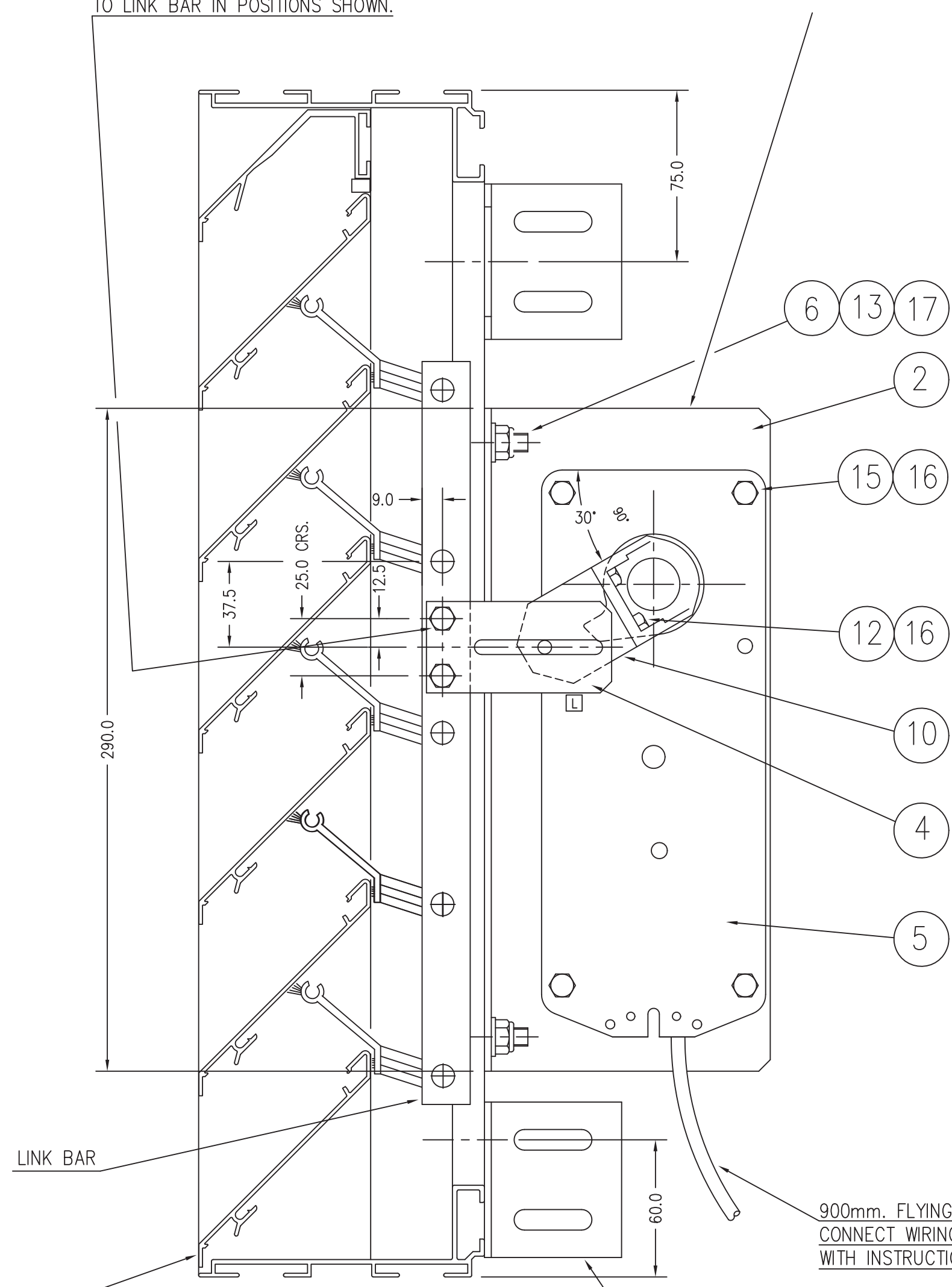

LOUVRE SHOWN IN FAILSAFE POSITION ie., ELECTRICAL POWER TO MOTOR IS OFF.
VERTICAL SECTION THRO' SINGLE BANK.

NOTE!
ON UNITS AT THE MINIMUM HEIGHT OF 520mm. UP TO 594mm. THE BOTTOM FIXING BRACKETS TYPES 1;2or3 TO BE FITTED ON TOP SLOT AT DIMENSION SHOWN. THIS WILL ALSO APPLY TO LARGER UNITS IF THE MOTOR IS POSITIONED AT THE 3rd. PITCH FROM THE BOTTOM OF THE LINK BAR. OTHERWISE BOTTOM FIXING BRACKETS CAN BE POSITIONED AT SIMILAR DIMENSIONS AS TOP BRACKETS i.e., 75mm. FROM OUTSIDE OF FRAME TO CENTRAL SLOT ON BRACKET.

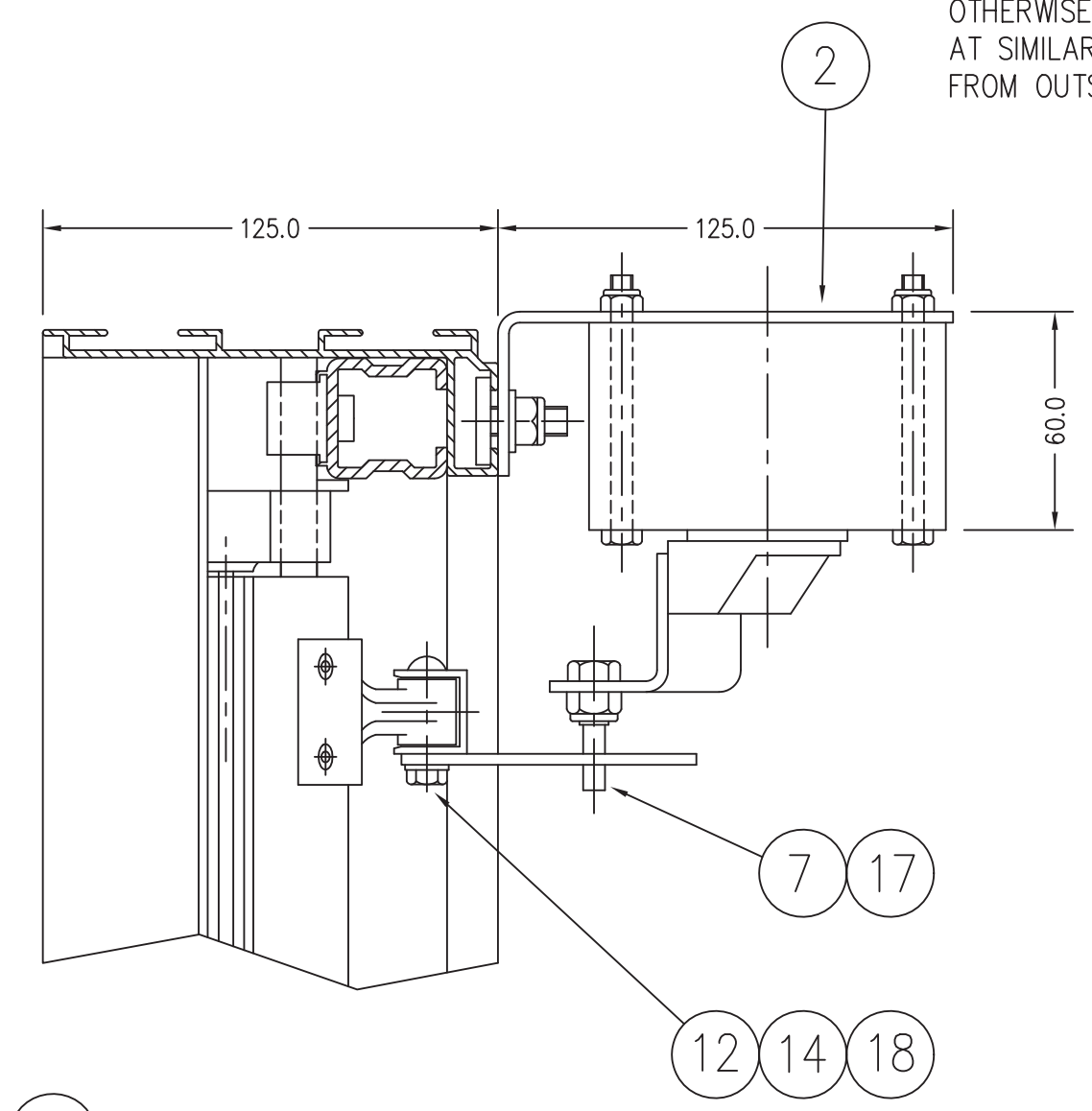

A SINGLE BANK

NOTES

- MINIMUM HEIGHT OF LOUVRE PANEL WITH THIS TYPE OF CONTROL IS 520mm.
- IN HOUSE ADJUSTMENT OF MOTOR FOR "FAIL SAFE CLOSE" OPERATION.
 - FIT MOTOR CONTROL ARM ITEM 10 COMPLETE WITH SPECIAL BOLT ITEMS 7&17 TO MOTOR SPINDLE.
 - VIEW MOTOR ON SIDE WITH "L" SHOWING.
 - WITH MOTOR IN UN-POWERED POSITION i.e., AT 0° FIT MOTOR SPINDLE COMPLETE WITH MOTOR CONTROL ARM SO THAT ANGLE BETWEEN CONTROL ARM AND TOP EDGE OF MOTOR IS 30° AS SHOWN.
 - MOTOR TO BE FITTED TO MOUNTING BRACKET ITEMS 2 or 3 IN-HOUSE. "D" BOLTS ITEMS 6;13&17 TO BE FITTED FINGER TIGHT INTO MOUNTING BRACKET. MOTOR & BRACKET ASSEMBLY TO BE SUPPLIED LOOSE.
 - CONTROL ARM ITEM 4 TO BE FITTED TO LOUVRE LINK BAR.
- TO FIT MOTOR ASSEMBLY TO LOUVRE, MAKE SURE LOUVRE IS IN FULLY CLOSED POSITION AND LOCATE ASSEMBLY ONTO LOUVRE WITH OPERATING PIN LOCATED IN SLOT OF CONTROL ARM.
- FOR ELECTRICAL WIRING CONNECTIONS SEE TECHNICAL DATA DRG. No.375-795
- PLEASE SPECIFY VOLTAGE EITHER 24V AC/DC OR 230V AC. (MOTOR BODIES ARE IDENTICAL.)

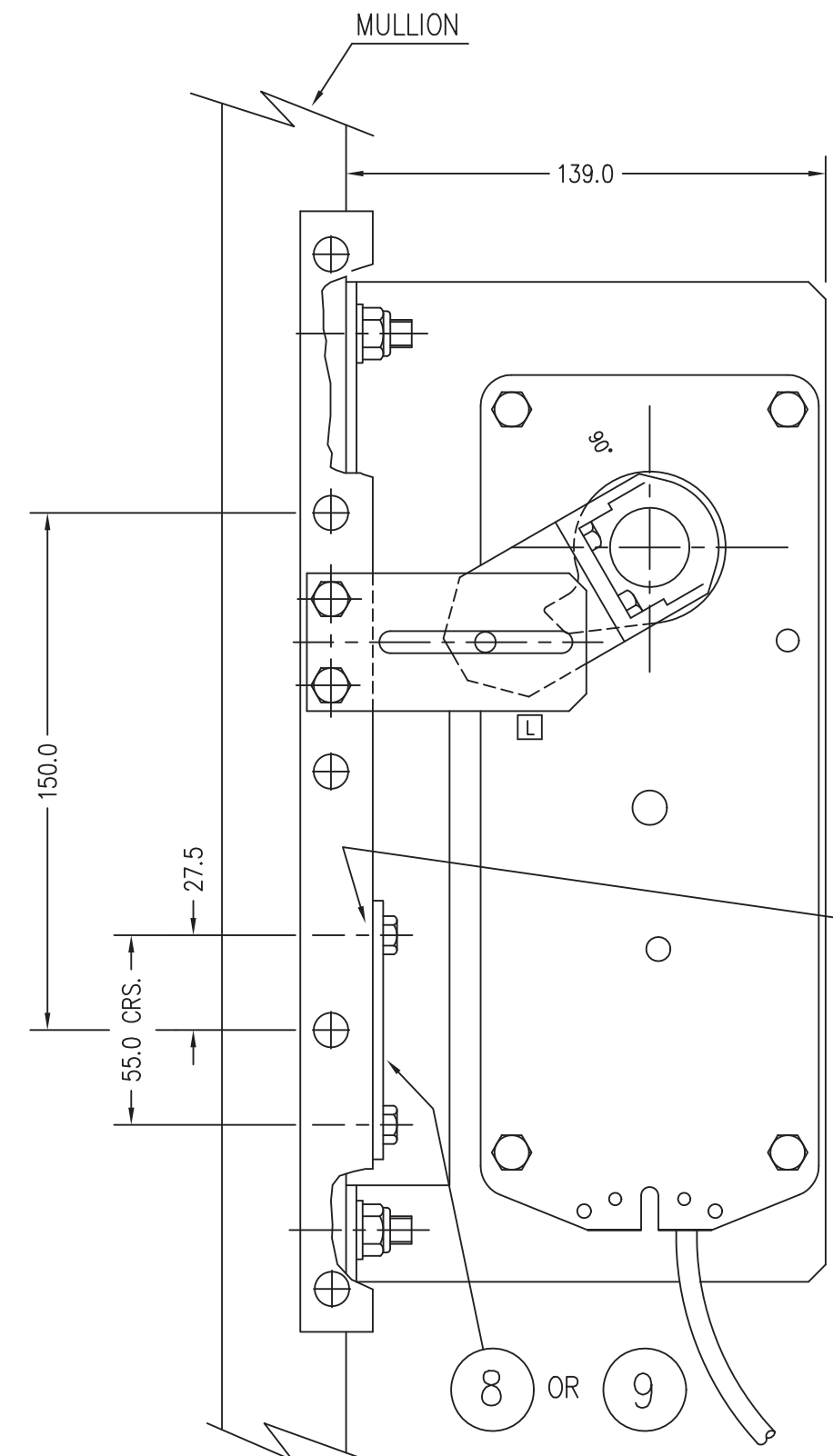

SIDE VIEW OF TYPES B&C MULTI-BANK SYSTEMS.
ALL OTHER DETAILS AS SINGLE BANK.

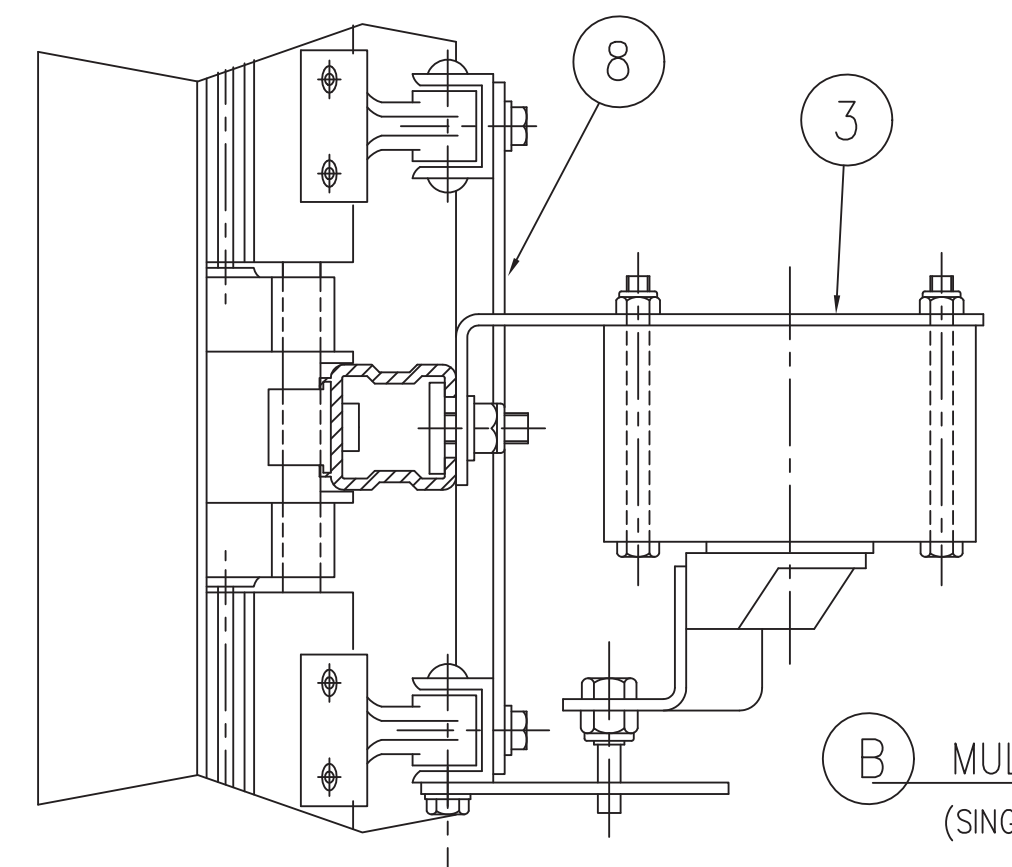

B MULTI-BANK (SINGLE MULLION)

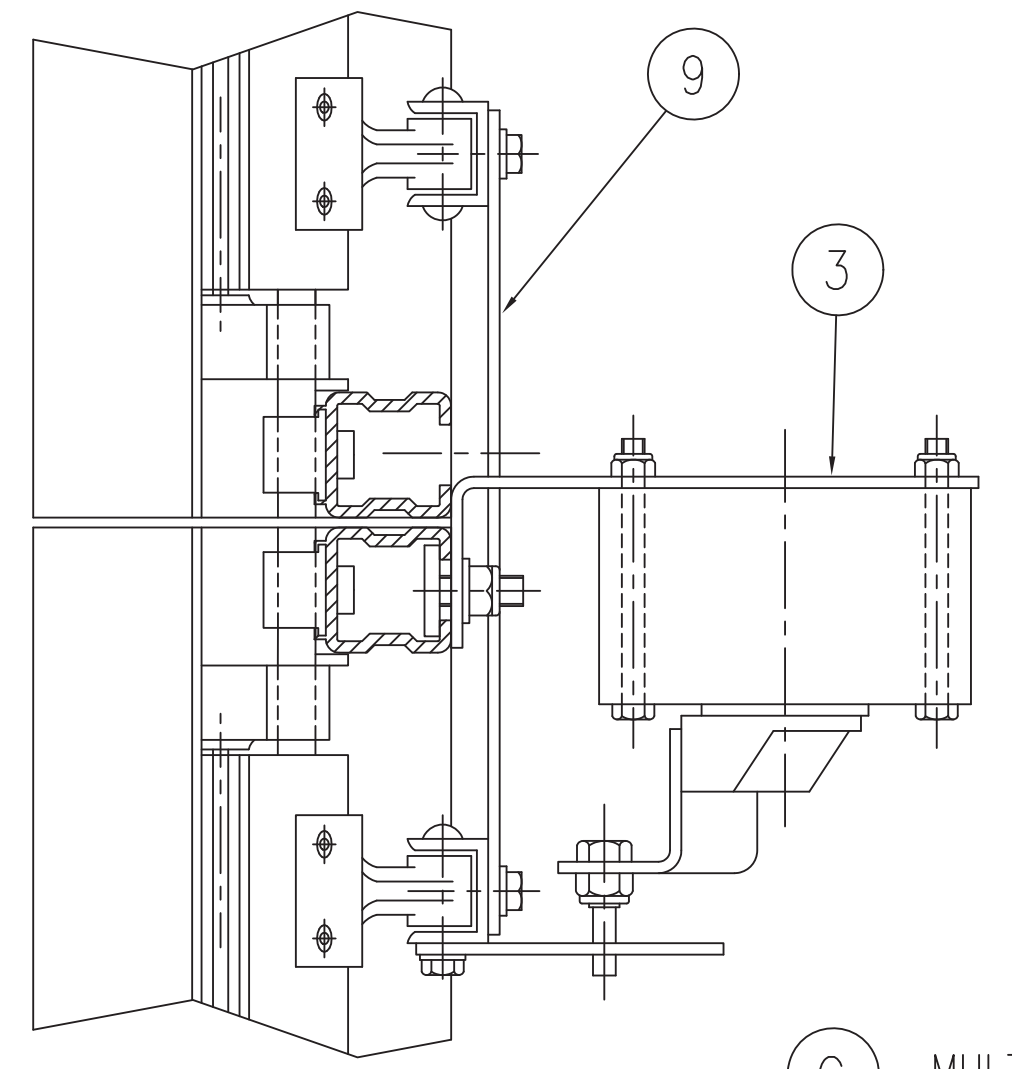

C MULTI-BANK (DOUBLE MULLION JOINT)

ITEM	DESCRIPTION	DRG.No./REMARKS	PART No.	ASSEMBLY		
				A No. OFF	B No. OFF	C No. OFF
1	LOUVRE ASSEMBLY	P375-750				
2	MOUNTING BRACKET TYPE A	P375-785	06-04-265	1	-	-
3	MOUNTING BRACKET TYPE B	P375-786	06-04-266	-	1	1
4	CONTROL ARM	P375-790	06-04-264	1	1	1
5	MOTOR 24V AC/DC ACTUATOR 230V AC	BELIMO TYPE AF24 BELIMO TYPE AF230	04-00-068 04-00-069	1	1	1
6	"D" BOLT 25mm. LONG	P375-033	06-04-184	2	2	2
7	SPECIAL BOLT	P375-789	06-04-261	1	1	1
8	CONNECTING PLATE TYPE B	P375-792	06-04-260	-	1	-
9	CONNECTING PLATE TYPE C	P375-793	06-04-259	-	-	1
10	MOTOR CONTROL ARM	P375-791	06-04-258	1	1	1
11	HEX.HD. SET SCREW	ST. STEEL M6 x 20lg.	05-01-483	2	6	6
12	HEX.HD. SET SCREW	ST. STEEL M6 x 16lg.	05-01-552	2	2	2
13	FLAT WASHER	ST. STEEL M8	05-01-453	2	2	2
14	SPRING WASHER	ST. STEEL M6	05-01-618	2	6	6
15	HEX.HD. BOLT	ST. STEEL M6 x 70lg.	05-01-872	4	4	4
16	NYLOC NUT	ST. STEEL M6	05-01-624	6	6	6
17	NYLOC NUT	ST. STEEL M8	05-01-625	3	3	3
18	BLIND FASTENER	PUL-SERT M6-0-C	05-07-074	2	6	6

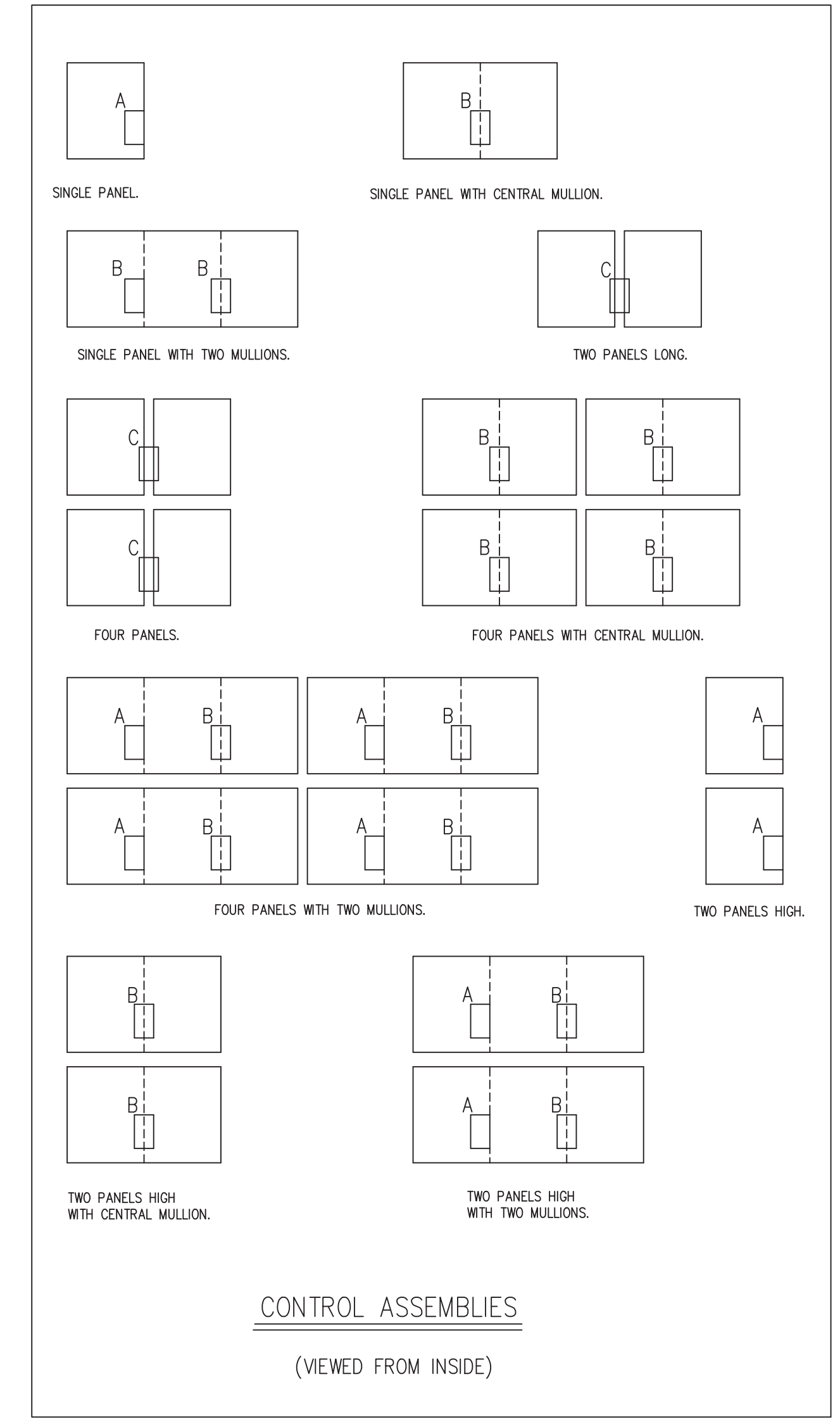

CONTROL ASSEMBLIES
(VIEWED FROM INSIDE)

LOUVRE TYPE :
TRIM TYPE :
GUARD TYPE : BIRDCUARD
PAINT TYPE : POLYESTER POWDER PAINT
FINISH : MATT/GLOSS
COLOUR :
LOCATION :
CUSTOMERS REF :
GAV REF :

DO NOT SCALE DRAWING, IF IN DOUBT ASK.
ALL DETAILS & DIMENSIONS MUST BE CONFIRMED AS CORRECT BEFORE MANUFACTURE OF LOUVRES CAN COMMENCE.
CUSTOMER DRAWINGS USED :-

Rev	Description	Mod. By	Date

© COPYRIGHT 2009 HUNTER PRODUCTS
THIS DRAWING A DESIGN ARE THE PROPERTY OF HUNTER PRODUCTS GROUP. AND MUST NOT BE COPIED OR USED IN ANY WAY PREJUDICIAL TO THEIR INTERESTS.

Project
Customer
Drawing Title

Location/Panel Ref.
Drawing No. Sheet No. Revision

Scale Date
Computer File No. Project No.
Drawn By Checked By
Coordinated By Approved By